

LINK[®] MORTUARY
EQUIPMENT

ASSEMBLY INSTRUCTIONS AND PARTS LIST

FC50 FLOWER CART (78014B00)

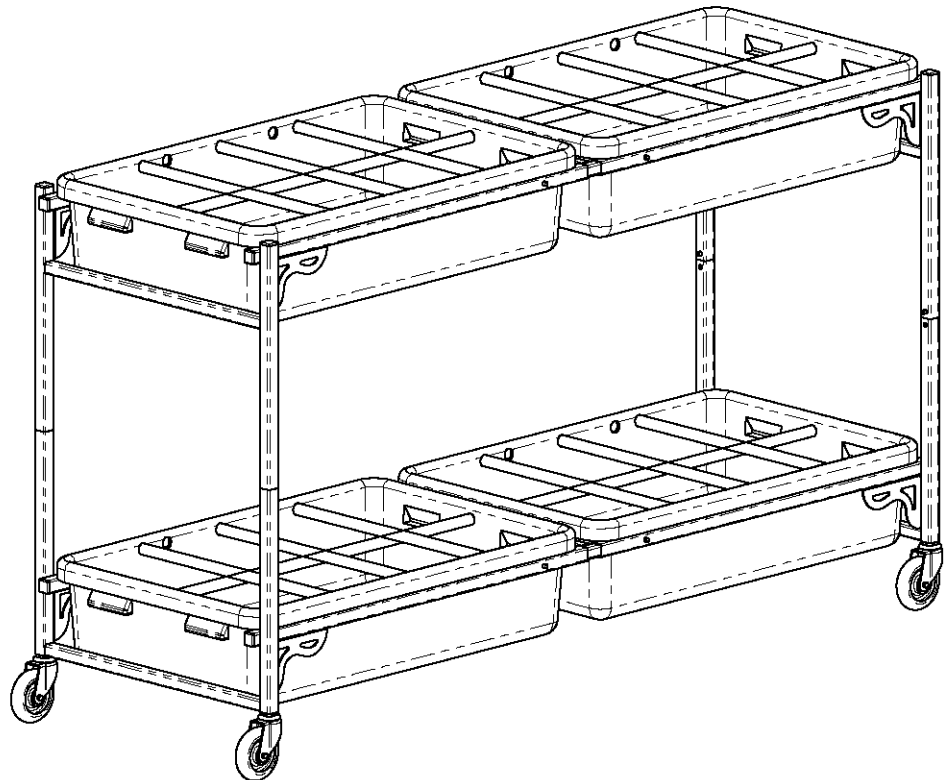

223 15th St. N.E.
Sioux Center, IA USA
51250-2120
www.linkmortuaryequipment.com

**QUESTIONS?
CALL CUSTOMER
SERVICE
1-800-248-3057**

Estimated weight : 81 lbs.

Link Mortuary Equipment, a division of Link Mfg., Ltd.
www.linkmortuaryequipment.com

78012111
AUG 4, 2023

IMPORTANT: IT IS IMPORTANT THAT THE ENTIRE INSTALLATION INSTRUCTIONS BE READ THOROUGHLY BEFORE PROCEEDING WITH THE INSTALLATION.

1. INTRODUCTION

Thank you for choosing a Link Mortuary Equipment FC50 Flower Cart. We want to help you get the best results from this cart and to operate it safely. This instruction contains information to assist in the installation of the Link Mortuary Equipment FC50. This instruction is intended solely for use with this product.

All information in this instruction is based on the latest information available at the time of printing. Link Manufacturing reserves the right to change its products or manuals at any time without notice.

Damaged components should be returned to Link with a pre-arranged Returned Materials Authorization (RMA) number through the Customer Service Department. The damaged component may then be replaced if in compliance with warranty conditions.

Assembly:

- A. A. The FC50 is shipped disassembled for shipping purposes. Assemble the two halves of the Lower frame
- B. (Item #7) using frame Crossmember (Item #9).
- C. B. Repeat for Upper frame (Item #8)
- D. C. Assemble the Lower and Upper frames to each other.
- E. D. Insert the Casters (Items #1) as shown. Install the dividers in the trays as desired, and the FC50 is ready
- F. to use!
- G. E. Call Link Mfg. at 1-800-248-3057 with any questions or comments.

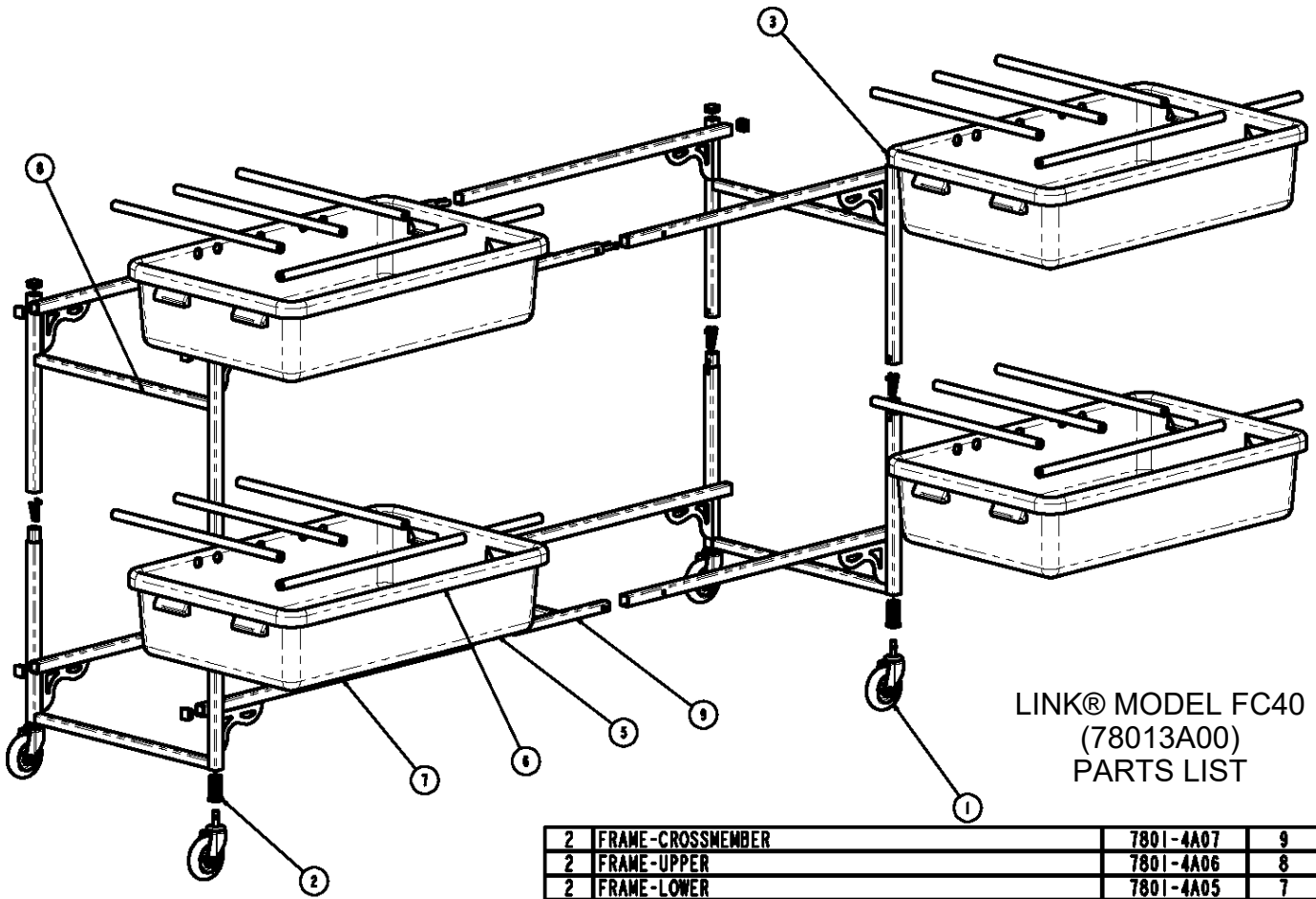

LINK® MODEL FC40
(78013A00)
PARTS LIST

2	FRAME-CROSSMEMBER	7801-4A07	9
2	FRAME-UPPER	7801-4A06	8
2	FRAME-LOWER	7801-4A05	7
4	FT2234 FLOWER TRAY W/ DIVIDERS	7800-0018	6
12	BUTTON-SNAP, SPRING LEG	1506-0202	5
1	BOX (10.00 X 4.00 X 4.00)	1500-1231	-
1	BOX(37 7/8 X 24 7/8 X 19)	1500-1187	-
1	INSTRUCTIONS-INSTALLATION	78012111	4
12	PLUG, 1 INCH SQ. X 18 GA	15070057	3
4	PLUG-CASTER, 1 INCH SQ.	15040033	2
4	CASTER-4 INCH, WO/ BRAKE	15040031	1



223 15TH ST. NE, SIOUX CENTER, IA 51250

1-800-248-3057

www.linkmortuaryequipment.com