

LINK® MORTUARY EQUIPMENT

OPERATION & MAINTENANCE MANUAL

DD2000-XLC 7226A000

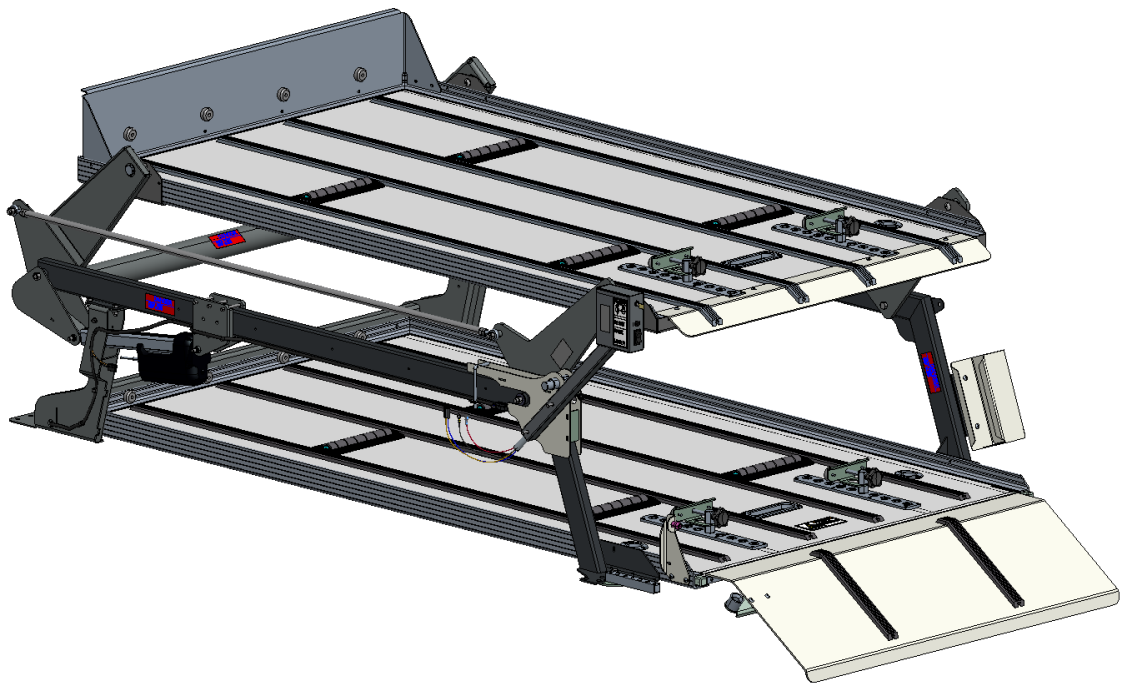

223 15th St. N.E.
Sioux Center, IA USA
51250-2120
www.linkmortuaryequipment.com

**QUESTIONS?
CALL CUSTOMER
SERVICE
1-800-248-3057**

Link Mortuary Equipment, a division of Link Mfg., Ltd.
www.linkmortuaryequipment.com

72262112
AUG 4, 2023

IMPORTANT: IT IS IMPORTANT THAT THE ENTIRE INSTALLATION INSTRUCTIONS BE READ THOROUGHLY BEFORE PROCEEDING WITH THE INSTALLATION.





1. INTRODUCTION

Thank you for choosing a Link Mortuary Equipment DD2000-XLC Double Deck system. We want to help you to get the best results from the deck and to operate it safely. This manual contains information to introduce you to the Link Mortuary Equipment DD2000-XLC and to assist you with its operation. The manual is intended solely for use with this product.

All information in this manual is based on the latest information available at the time of printing. Link Manufacturing reserves the right to change its products or manuals at any time without notice. Contact Link Mortuary Equipment at (800) 248-3057 for information on recent changes to products.

Damaged components should be returned to Link with a pre-arranged Returned Goods Authorization (RGA) number through the Customer Service Department. The damaged component may then be replaced if in compliance with warranty conditions.

2. SAFETY SYMBOLS, TORQUE SYMBOL, and NOTES

 DANGER	DANGER indicates a hazardous situation which if not avoided, will result in death or serious injury.
 WARNING	WARNING indicates a potentially hazardous situation which, if not avoided, could result in death or serious injury.
 CAUTION	CAUTION indicates a potentially hazardous situation which, if not avoided, could result in minor or moderate injury.
 NOTICE	NOTICE indicates a potentially hazardous situation which, if not avoided, may result in property damage.
 TORQUE	TORQUE indicates named fasteners are to be tightened to a specified torque value.
NOTE:	A Note provides information or suggestions that help you correctly perform a task.

3. SAFE WORKING PRACTICES

 **WARNING** Link products must be installed by a trained technician when being placed into an Electric Vehicle (EV). Electric Vehicles have higher voltage batteries and cables, and drilling into Electric Vehicles may cause serious bodily harm and possible death.

 **WARNING** **NOTE: Link is not responsible for optional configurations or equipment that restrict the installation of the product in any way. Consult OEM body builder guides for additional installation guidelines.**

 **CAUTION** When handling parts, wear appropriate gloves, eyeglasses, ear protection, and other safety equipment.

 **CAUTION** Proper tightening of fasteners is important to the performance and safety of the suspension. Follow all torque specifications throughout the instructions.

 **CAUTION** Practice safe lifting procedures.

 **CAUTION** The deck weldments are heavy, and can cause injury if lifted improperly or dropped. Consider size, shape, and weight of objects being moved.

 **CAUTION** Obtain help or the assistance of a crane when lifting heavy assemblies. Make certain the path of travel is clear.

4. OPERATION GUIDELINES

4.1 In order for this deck to operate properly, it must operate in the parameters specified by Link.

4.2 No alterations of any Link deck component is permitted without proper authorization from qualified Link personnel.

5. INTRODUCTION

⚠ WARNING Make certain the vehicle is in park and the parking brake is engaged before loading / unloading the vehicle.

⚠ WARNING Vehicle movement during loading / unloading could cause operator injury or death.

⚠ WARNING The capacity of the top deck is **600 pounds maximum**, evenly distributed.

⚠ WARNING Loading beyond the capacity may result in equipment damage or failure that may result in injury or death.

5.1 Top Deck Controls & Operation

Immediately inside the rear doors against one of the side walls is the top deck control box.

There are three items on the control box:

- System Lock On/Off switch (with key)
- Top Deck Raise / Lower Rocker Switch
- Circuit Breaker Reset Button

Operation:

- To operate the deck, turn the power key to the “ON” position.
 - Push the rocker switch to “RAISE” to raise the deck.
 - To lower the top deck, push the rocker switch to “LOWER”.
- Turn the power switch to the “OFF” position and remove the key when you are finished operating the deck.

⚠ CAUTION The System Lock On/Off key switch should be turned to off and the key removed if the unit is left unattended to prevent unauthorized use.

5.2 Loading / Unloading Procedure

1. With the vehicle in park and the parking brake secured, open the rear door of the vehicle.
2. Fold down the rear ramp.

⚠ CAUTION Make certain that the deck latch is in the stowed position before lowering or raising the deck

3. If the top deck is to be used and is in the up position, lower the top deck by following the procedures outlined in **Step 5.1** of this manual.

⚠ CAUTION Make certain that the load is properly secured by properly tightening the bier pin(s).

⚠ CAUTION Caskets placed on both the top and bottom deck are prevented from lateral movement by the friction of the front bumpers combined with the clamping force of the bier pin.

4. Slide the items to be transported on to the top deck, taking care to evenly distribute the load as best as possible. Secure items with the bier pins (if caskets) or by placing the legs in the cups (hospital cots).
5. Raise the top deck and place items to be transported on the bottom deck, taking care to properly secure the load.
6. Turn the System Lock On/Off Switch to “OFF” and remove the key.
7. Move the Deck Latch into supporting position.
8. Raise the rear ramp.
9. Close the rear doors.
10. Reverse the procedure for unloading.

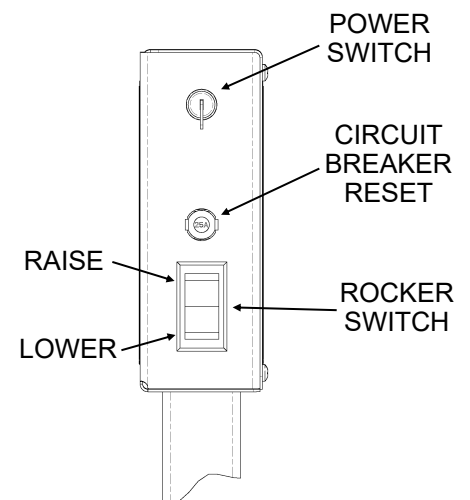

6. MAINTENANCE

⚠ CAUTION Park the vehicle in a level, flat area, and apply the parking brake before performing any maintenance.

⚠ CAUTION Turn the “System Lock” key switch to the “Off” position and remove the key before performing any maintenance.

⚠ CAUTION Perform maintenance work from outside the deck, whenever possible.

The DD2000-XLC is designed to last for many years without any major maintenance. Periodically, check the following items:

Each Time the System is Used:

- Listen for unusual noises and watch to ensure proper movement of the system. If there is a problem, correct it before continuing to use the system.

Annually:

- Check tightness of all fasteners. (Refer to Torque Table below)
- Visually inspect for cracks or damage at all pivots on the framework and torsion bar and replace pivot bushings or pins if necessary.
- Grease deck-latch pin if necessary
- Check for cracks in the framework and decks and repair or replace if necessary.
- Verify that the electrical control system functions as intended.

⚠ CAUTION Perform these checks with the Upper Deck lowered.

TORQUE TABLE	
FASTENER	TORQUE
1/4-UNC NUTS	6-8 FT-LBS
5/16-UNC NUTS	15-25 FT-LBS
3/8-UNC NUTS	30-40 FT-LBS
7/16-UNC NUTS	50-60 FT -LBS
1/2-UNC NUTS	80-100 FT-LBS

7. SERVICE

Procedure for replacing an inoperative actuator:

1. If the deck is lowered, or can be lowered, skip to step 6. If the deck is raised and stuck, complete steps 2 through 5 before proceeding.

CAUTION Park the vehicle in a level, flat area, and apply the parking brake before performing any maintenance.

CAUTION Turn the "System Lock" key switch to the "Off" position and remove the key before performing any maintenance.

CAUTION Perform maintenance work from outside the deck, whenever possible.

2. If the deck is loaded, remove the load if possible.
3. Place jack stands or blocks under the top deck to support it in the raised position while preparing it to be lowered.
4. If necessary, use a jack or forklift to lift the top deck slightly, to free the actuators and actuator pivot bolts.
5. Disconnect the inoperative actuator(s) from the control wiring harness. Unfasten the inoperative actuator(s) from the torsion arm weldment and the actuator mount.

WARNING The top deck will be free to move if both actuators are disconnected from the torsion arm, and **Will Fall if Unsupported.**

WARNING Do NOT force out the actuator pivot bolts. If the pivot bolts are difficult to remove they may still be supporting the top deck. When the load is removed from the actuators the pivot bolts will be easy to remove.

6. Check that no persons or objects are on the lower deck, or in the cargo area, then remove the supports and carefully lower the top deck. If one actuator is still functioning and connected, lower the top deck using the normal operating procedure. **NOTE: One actuator is sufficient to safely lower the top deck, but does not have the capacity to raise the top deck while loaded.**
 - If both actuators were non-functioning and disconnected, use a jack or forklift to carefully lower the top deck onto wood blocks placed on top of the lower deck. The top deck should be held 1-2 in. above the lower deck.
7. Extend the replacement actuator(s) with an auxiliary 12 volt source, and fit the new actuator(s) to the actuator mount and torsion arm.

TORQUE 8. Connect the new actuator(s) to the control wiring harness. Ensure that all persons are clear of the cargo area, and test the operation of the deck through several cycles.

Procedure for clearing blockages in the DD-2000-XLC:

1. If the deck is loaded, remove the loads, and lower the top deck, if possible.
2. If the top deck is in the raised position, place jack stands under the top deck for support.
3. Remove the blockage, working from above the upper deck or from the side door, if possible.

CAUTION Park the vehicle in a level, flat area, and apply the parking brake before performing any maintenance.

CAUTION Turn the "System Lock" key switch to the "Off" position and remove the key before performing any maintenance.

CAUTION Perform maintenance work from outside the deck, whenever possible.

4. Inspect the decks, frame, and mechanism for damage.
5. Ensure that all persons are clear of the cargo area, and remove the jack stands.
6. Test the operation of the deck through several cycles.

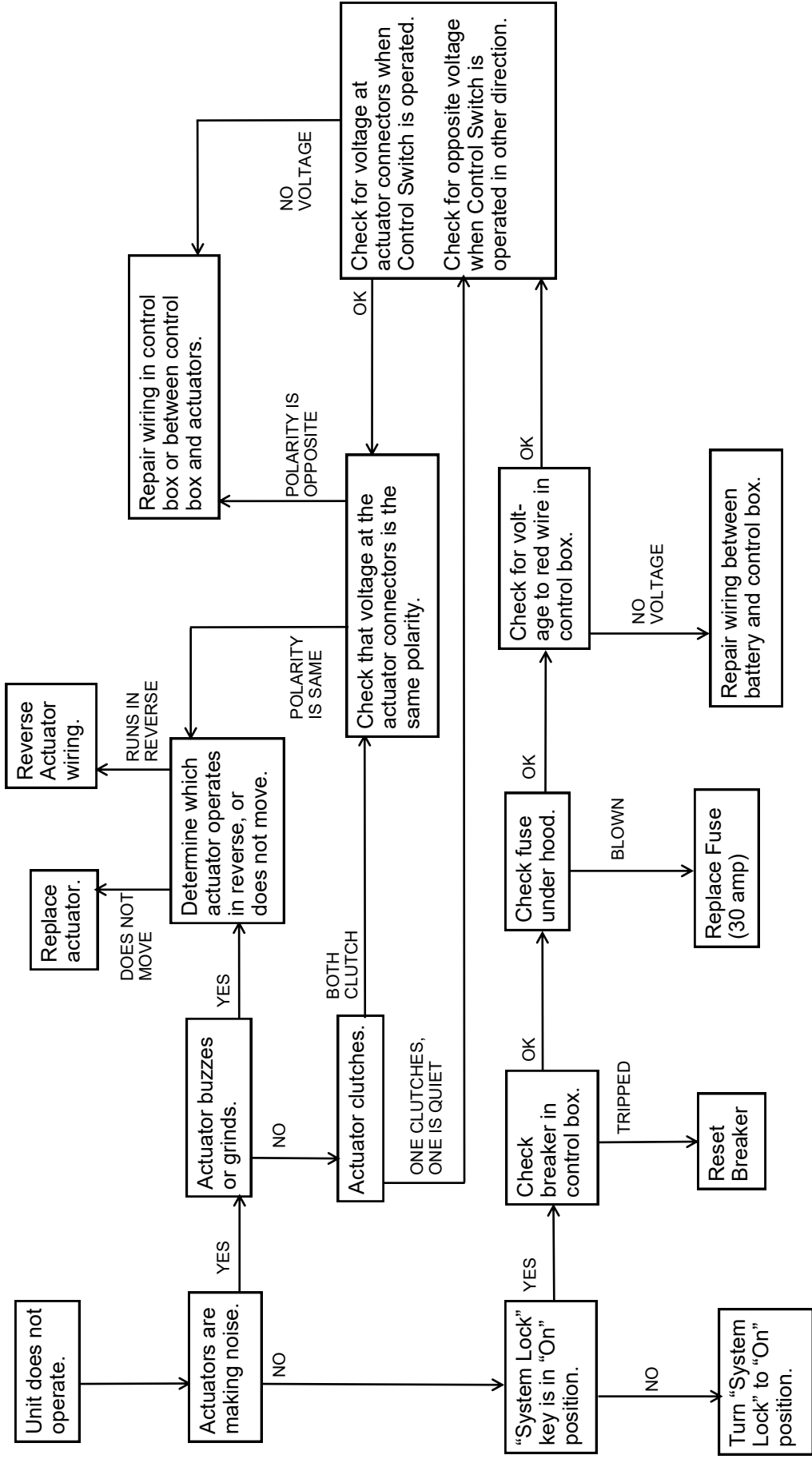

DD-2000-XLC Electrical Troubleshooting Diagram

**Replacement fuses are standard blade type fuses and can be found at your local automotive parts store.

DD2000-XLC ASSEMBLY
PN: 7226A000

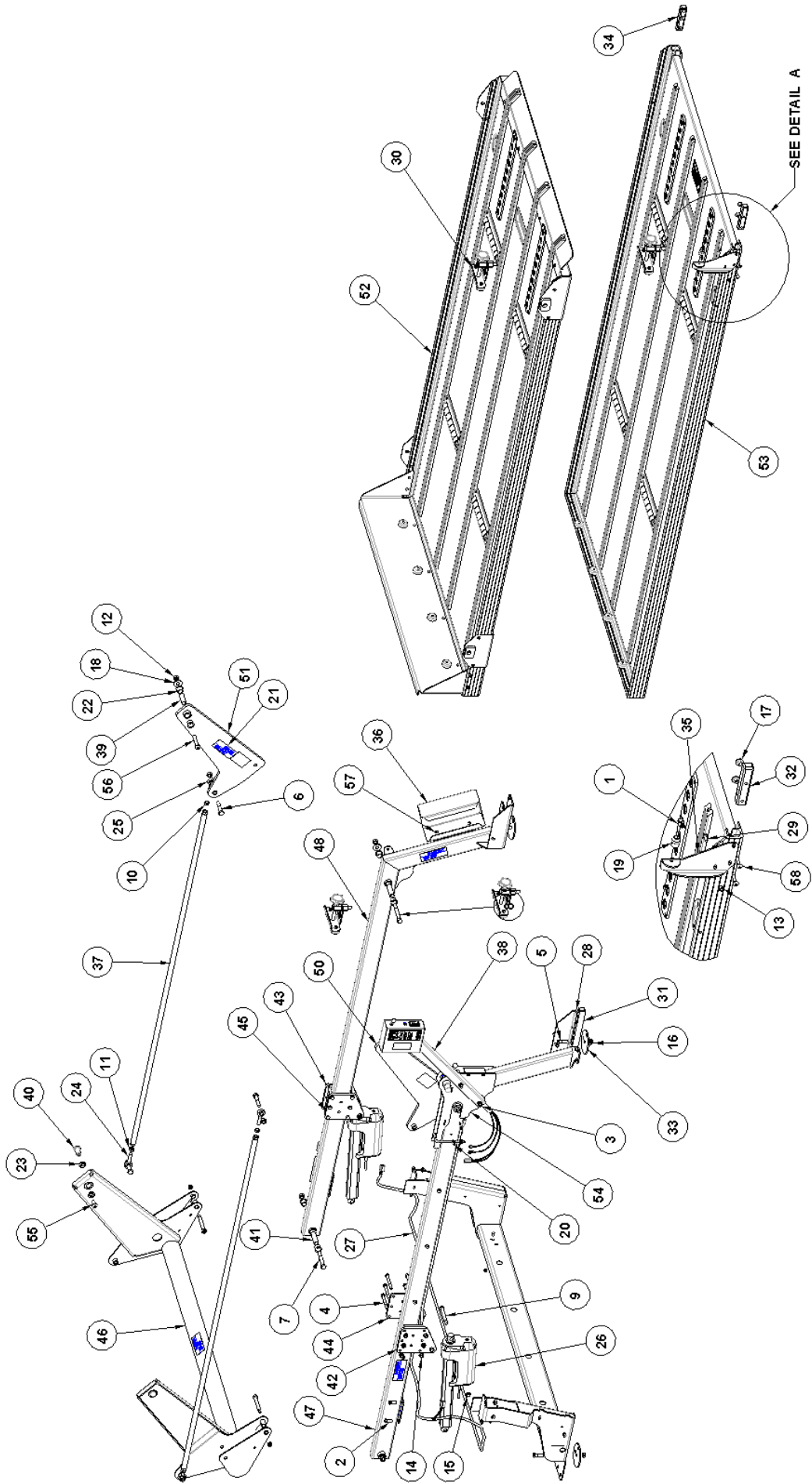

ITEM	DESCRIPTION	QTY	ITEM	DESCRIPTION	QTY
1	1/4 X 1 1/4 UNC HEX CAP SCR	1	30	PIN-BIER, ADJUSTABLE	4
2	3/8 X 1 UNC HEX CAP SCR	4	31	BIER PIN HOLDER	2
3	3/8 X 2 1/2 UNC HEX CAP SCR	2	32	TUBE-MOUNT, RAMP	1
4	3/8 X 3 1/4 UNC HEX CAP SCR	12	33	WASHER-FLOOR SUPPORT	4
5	7/16 X 1 1/2 UNC HEX CAP SCR	4	34	TUBE-MOUNT, RAMP	1
6	1/2 X 2 1/2 UNC HEX CAP SCR	4	35	BRACKET-STOP, RAMP	1
7	1/2 X 3 1/2 UNC HEX CAP SCR	2	36	HOLDER-GLOVE BOX	1
8	1/2 X 4 UNC HEX CAP SCR	2	37	TIE ROD WELDMENT	2
9	SHSCS-.500X3.250	4	38	ASSEMBLY-CONTROL BOX, DD2000	1
10	1/2 UNF HEX JAM NUT	2	39	BUSHING-PIVOT	2
11	1/2 UNF HEX JAM NUT LH THREADS	2	40	PIN-PIVOT	2
12	1/2 UNC HEX CTR LOCK NUT	10	41	PIN-PIVOT	4
13	1/4 UNC HEX NYLOCK NUT	8	42	BRACKET-MOUNT, ACTUATOR OUTSIDE DRIVER	1
14	3/8 UNC SERRATED FLANGE NUT	18	43	BRACKET-MOUNT, ACTUATOR OUTSIDE PASS.	1
15	3/8 UNC TOP LOCK FL NUT	4	44	BRACKET-MOUNT, ACTUATOR INSIDE DRIVER	1
16	7/16 UNC SERRATED FLANGE NUT	4	45	BRACKET-MOUNT, ACTUATOR INSIDE PASS.	1
17	NUT 1/4-20 X 7/16 HT PROPELLER TEE	4	46	WELDMENT-BAR, TORSION	1
18	1/2 TYPE A PLAIN WASHER	4	47	WELDMENT-FRAME, LEFT	1
19	RAMP HOLDER, MALE END	1	48	WELDMENT-FRAME, RIGHT	1
20	CLIP-LATCHING	10	49	WELDMENT-CROSSMEMBER	1
21	DECAL-PINCH POINT	7	50	SWING-ARM, REAR	1
22	BUSHING-PIVOT, NYLON	12	51	SWING-ARM, REAR	1
23	BUSHING-PIVOT, NYLON, 3/8	4	52	DECK-TOP	1
24	ROD END-SPHERICAL, LEFT HAND	2	53	DECK-BOTTOM	1
25	ROD END-SPHERICAL, RIGHT HAND	2	54	LATCH-KIT, DD2000	1
26	ACTUATOR, 12V, 300MM STROKE, 6800N	2	55	1/2 X 1 UNC SOCKET BUTTON HD CAP SCR	2
27	HARNESS-ACTUATOR	1	56	1/2 X 2 3/4 UNC SOCKET BUTTON HD CAP SCR	2
28	#6 X 1 DRYWALL SCREW W/ DRILL POINT	6	57	1/4 X 1/2 UNC TRUSS HD PH MACH SCR	2
29	1/4-20 X 3/4 BUTTON HD CAP SCREW	5	58	1/4 X 1 1/4 UNC TRUSS HD PH MACH SCR	4

BOTTOM DECK ASSEMBLY

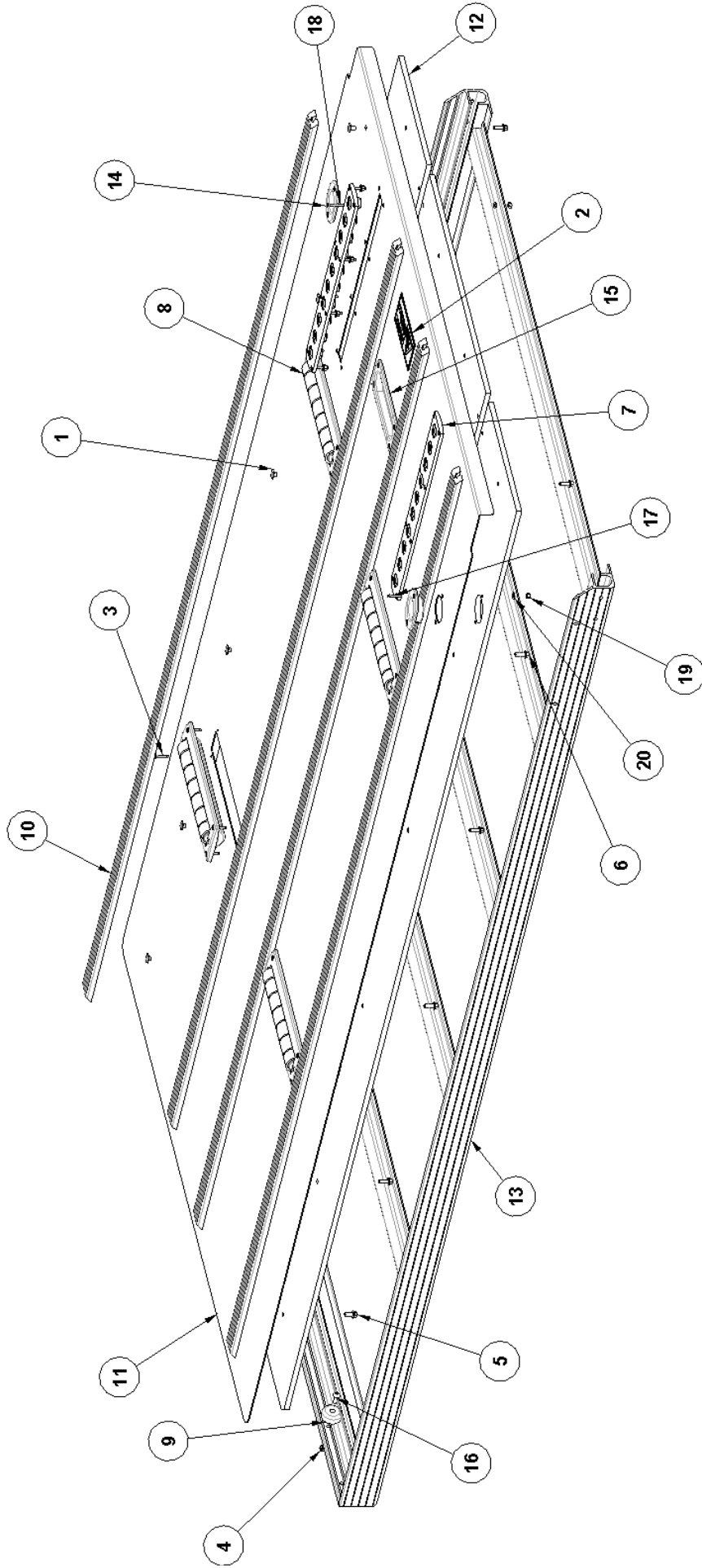

ITEM	DESCRIPTION	QTY	ITEM	DESCRIPTION	QTY
1	1/4-20 X 7/16 SLAB BASE WELD NUT	24	11	SHEET-DECK	1
2	LABEL-WARNING, DOUBLE DECK	1	12	BOARD-DECK	1
3	#10 X 1 SS FLAT HD TYPE B TAP SCR	16	13	FRAME-DECK, BOTTOM	1
4	1/4 UNC HEX THIN NYLOCK NUT	4	14	RECESSED COT CUP	2
5	1/4 X 5/8 FLANGE HEAD BOLT	4	15	SUPER SIZED RECESSED COT CUP	1
6	1/4 X 3/4 FLANGE HEAD BOLT	20	16	1/4 X 3/4 UNC TRUSS HD PH MACH SCR, SS	4
7	BIER PIN PLATE	2	17	8-32 X 1 OVAL HD MACH SCR-SS	8
8	CR60 CASKET ROLLER	4	18	8-32 X 1 1/4 OVAL HD MACH SCR-SS	16
9	BUMPER-RECESSED, 1.50 O.D. X .63 H	4	19	8-32 UNC HEX NYLOCK NUT, GR B, ZINC PLT	24
10	GLIDE STRIP	4	20	#10 SAE PLAIN WASHER	24

TOP DECK ASSEMBLY

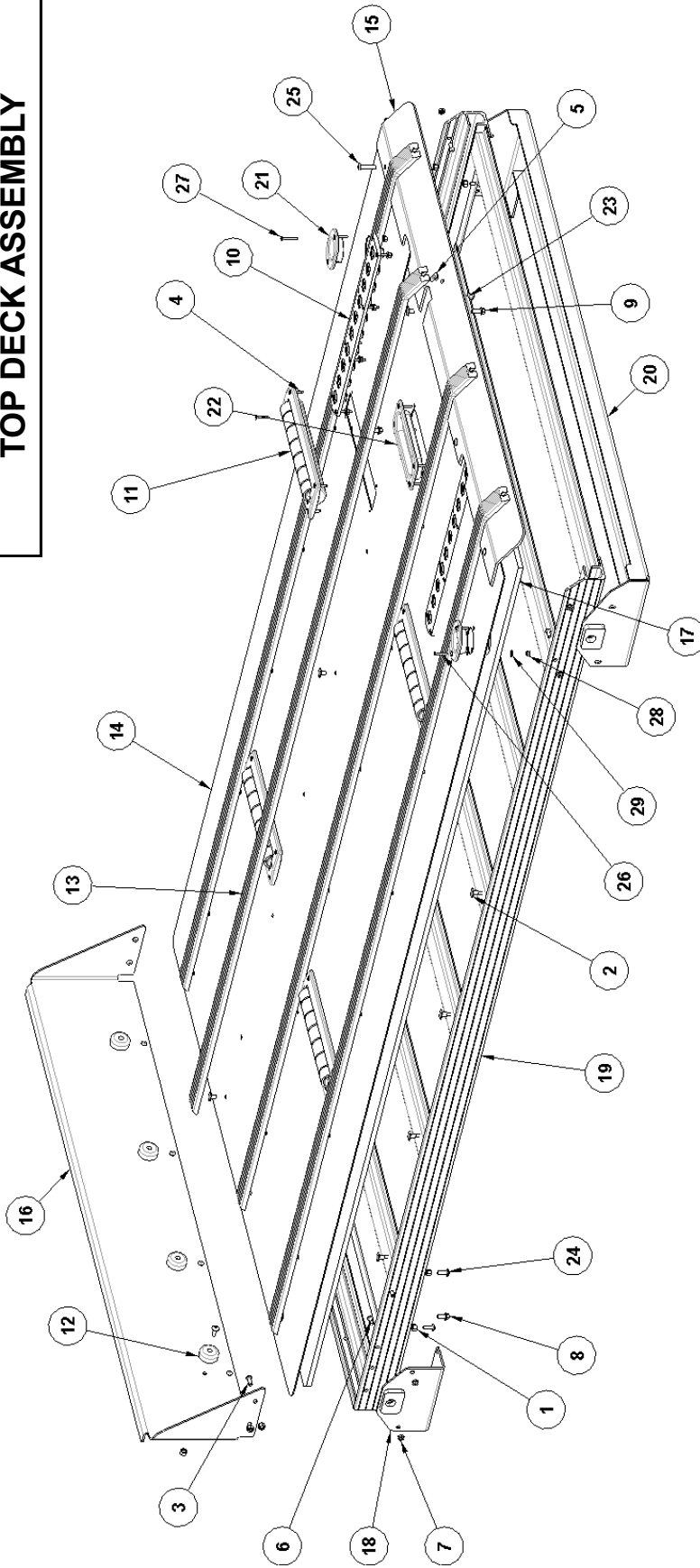

ITEM	DESCRIPTION	QTY	ITEM	DESCRIPTION	QTY
1	1/4 UNC HEX NYLOCK NUT (GR B)	22	16	BRACKET-IMPACT, FRONT	1
2	1/4-20 X 7/16 SLAB BASE WELD NUT	32	17	BOARD-DECK	1
3	1/4-20 X 3/4 SOCKET BUTTON HD SS CAP SCREW	8	18	BRACKET-PIVOT, TOP	2
4	#10 X 1 SS FLAT HD TYPE B TAP SCR	16	19	FRAME-DECK, TOP	1
5	1/4-20 X 1/4 SLAB BASE WELD NUT	4	20	BRACKET-PIVOT, TOP	1
6	1/4-20 X 5/8 SOCKET BUTTON HD CAP SCREW	8	21	RECESSED COT CUP	2
7	1/4 UNC HEX THIN NYLOCK NUT	8	22	SUPER SIZED RECESSED COT CUP	1
8	1/4 X 5/8 FLANGE HEAD BOLT	4	23	1/4 X 1/2 UNC TRUSS HD PH MACH SCR, SS	4
9	1/4 X 3/4 FLANGE HEAD BOLT	28	24	1/4 X 3/4 UNC TRUSS HD PH MACH SCR, SS	10
10	BIER PIN PLATE	2	25	1/4 X 1 1/4 UNC TRUSS HD PH MACH SCR, SS	4
11	CR60 CASKET ROLLER	4	26	8-32 X 1 OVAL HD MACH SCR-SS	8
12	BUMPER-RECESSED, 1.50 O.D. X .63 H	4	27	8-32 X 1 1/4 OVAL HD MACH SCR-SS	16
13	GLIDE STRIP	4	28	8-32 UNC HEX NYLOCK NUT, GR B, ZINC PLT	24
14	SHEET-DECK	1	29	#10 SAE PLAIN WASHER	24
15	GUARD-ANGLE, REAR	1	-	-	-

